

Controlled by
FS100

The MOTOMAN MPP3S 4-axis high-speed robot with parallel kinematic system combines the speed of the delta design with a high payload capacity and a large working range. Due to the high torque of the fourth axis, the so-called wrist axis, the MOTOMAN MPP3S moves payloads of up to 3 kg at unprecedented speeds. This delta robot was developed for a wide spectrum of industries, such as food and beverage, pharmaceutical and the automotive sector.

The MPP3S is driven by YASKAWA's compact FS100 controller and is available with advanced technologies such as MotoSight, MotoPick and conveyor tracking.



Fraunhofer

**TESTED[®]
DEVICE**

Yaskawa Europe GmbH
MOTOMAN robot MPP3S
Report No. YA 1312-680

Key benefits

- ISO class 5 (ISO 14644-1), clean room rated
- Protection classification IP67
- Payloads with unprecedented speed:
 - 150 cycles per minute with 3 kg payload
 - 185 cycles per minute with 1 kg payload
- Total stroke of 300 mm with a working range of 800 mm
- High-precision, high-speed conveyor tracking
- Maximum machine accuracy
- Compact installation space: 684 mm diameter

MOTOMAN MPP3S

Handling, Picking and Packing

 **YASKAWA**

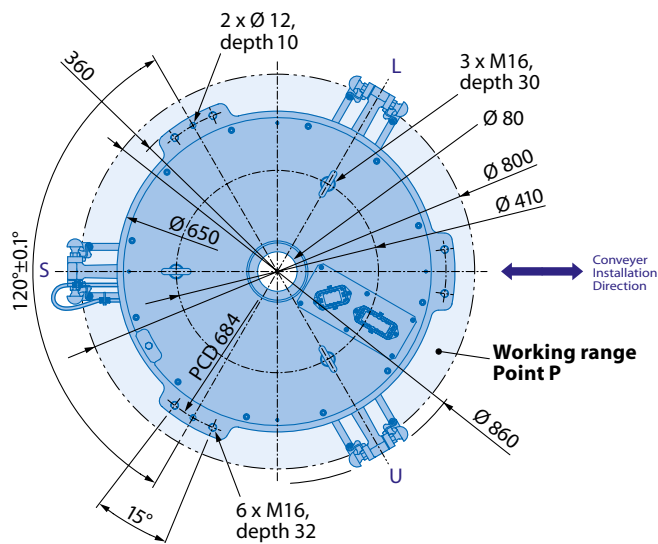
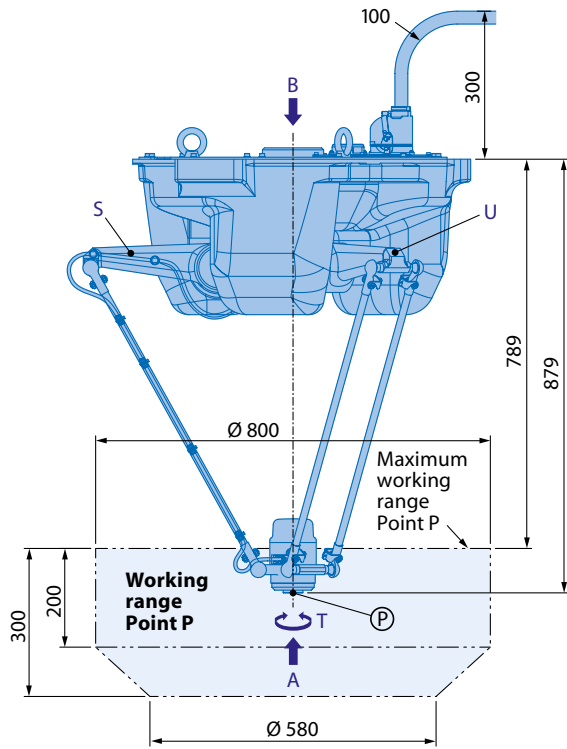

View A

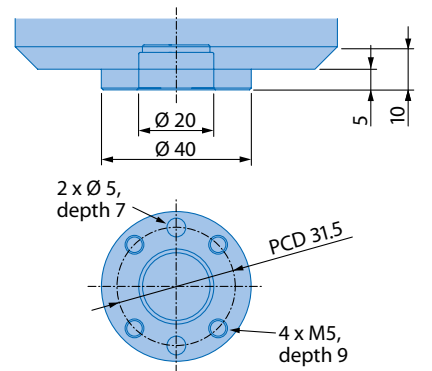

Allowable wrist load

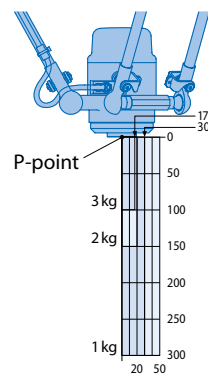

All dimensions in mm | Technical data may be subject to change without previous notice | For planning Multi-Robot-Systems please refer to your YASKAWA sales contact | Please request detailed drawings at robotics@yaskawa.eu – YR-MPP003S-A00, B-11-2014, A-No. 166332



Specifications MPP3S

Pattern	Payload [kg]	CPM*	Payload [kg]	CPM*	Controlled axes	4
25-305-25	1	230	3	170	Max. payload [kg]	3
300-400-100	1	100	3	80	Repeat. pos. accuracy [mm]	±0.1
70-700-70	1	130	3	95	Repet. rotational accuracy of T-axis [arc x min ⁻¹]	±1
Conveyor speed [mm/s]**		Conveyor position repeat accuracy [mm]**			Max. working range [mm]	D = 860
800		1			Temperature [° C]	0 to +40
1300		1.5			Humidity [%]	20 – 80
2000		3			Weight [kg]	95
					Power supply, average [KVA]	1.5
					IP class	IP67

* Cycle time without picking time and product.
 ** Values determined under test conditions, differences possible depending on application.



YASKAWA Headquarters

YASKAWA Europe GmbH
 Robotics Division
 Yaskawastraße 1
 D-85391 Allershausen
 Tel. +49 (0) 81 66/90-0
 Fax +49 (0) 81 66/90-103
robotics@yaskawa.eu
www.yaskawa.eu.com

YASKAWA academy and sales office Frankfurt

YASKAWA Europe GmbH
 Robotics Division
 Hauptstraße 185
 D-65760 Eschborn
 Tel. +49 (0) 6196/77725-0
 Fax +49 (0) 6196/77725-39
robotics@yaskawa.eu
www.yaskawa.eu.com