

CRX-10iA/L



Max. load capacity
at wrist: **10 kg**



Max. reach:
1418 mm

Controlled axes	Repeatability (mm)	Mechanical weight (kg)	Motion range (°)						Maximum speed (°/s) *2						J4 Moment/ Inertia (Nm/kgm ²)	J5 Moment/ Inertia (Nm/kgm ²)	J6 Moment/ Inertia (Nm/kgm ²)
			J1	J2	J3	J4	J5	J6	J1	J2	J3	J4	J5	J6			
6	± 0.05	≤ 39*1	360	360	540	380	360	380	120	120	180	180	180	180	34.8/1.28	26.0/0.90	11.0/0.30

Working range

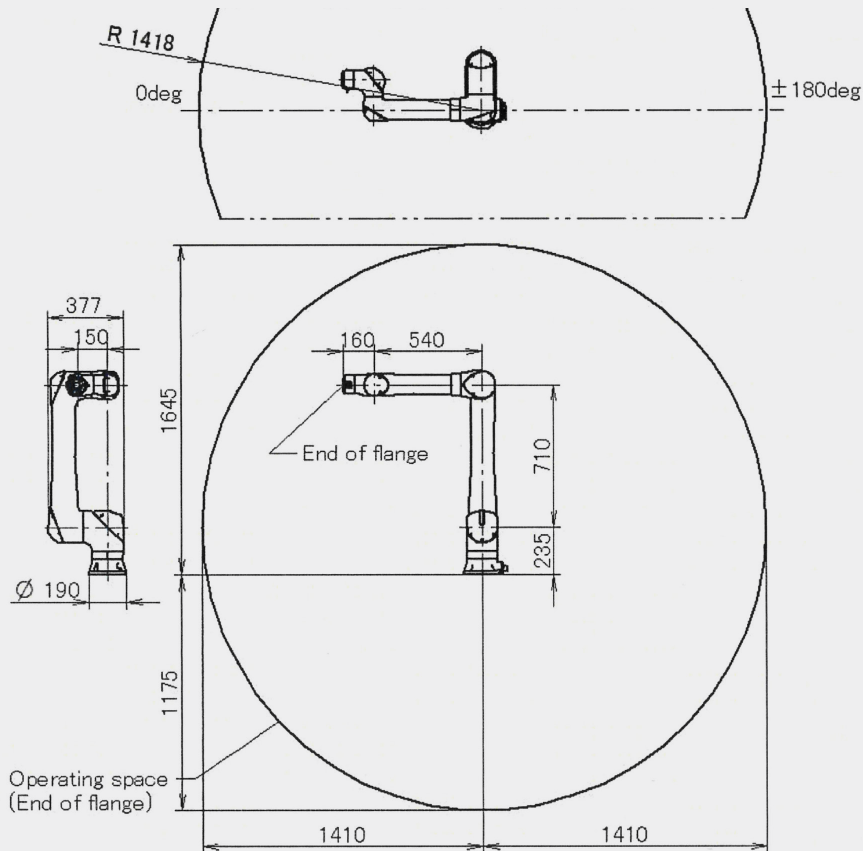

Robot

CRX-10iA/L

Robot footprint [mm]	190
Mounting position Floor	●
Mounting position Upside down	●
Mounting position Angle *3	●



Controller

R-30iB Plus

Mini Plus	●
Dimensions [mm]	420 x 290 x 370
Tablet TP	●

Electrical connections

Voltage 50/60Hz 3phase [V]	-
Voltage 50/60Hz 1phase [V]	200-230
Average power consumption [kW]	0.5

Environment

Ambient temperature [° C]	0-45
Ambient humidity [%]	≤ 75 *4
Ambient humidity - Short term [%RH]	≤ 95 *5
Vibration acceleration [m/s ²]	≤ 4.9 (0.5G)

Protection

IP54

*1) Without controller. Weight of controller ≤ 19 kg.

*2) During short distance motions, the speed may not reach the maximum value stated.

*3) In case of angle mount, motion range needs to be restricted according to the payload.

*4) No dew nor frost allowed.

*5) Within one month.

● standard ○ on request - not available () with hardware and/or software option